

Catalogue

HVAC Controllers
and Building Automation Systems



➤ Who we are

Setecna EPC srl starts its activity in 2002. Over the years Setecna has specialized in the electronic systems design and production to manage and control (also remotely) heating, cooling and domestic hot water production installations. These regulation and remote-control electronic systems can manage both the distribution of the energy in the building (indoor temperature, indoor air quality and humidity management) and the production of the energy in the thermal/cooling power stations (heat pumps and gas boilers management). We offer products and services for System Integrator, Installers, Maintainers and Energy Manager Companies.

We are able to design and produce customized solutions, combining the skills gained in 20 years of activity:

- Hardware design
- Software development on Windows, Linux and Web platforms
- Cloud supervision system development
- Firmware development on 8-bit (Atmel AVR) and 32-bit (ARM) microcontrollers
- Telecommunications on wired and mobile networks (GPRS, 4G, 5G)

Setecna EPC is a complete company with a technical-know-how acquired in almost 2 decades that allows to follow the customer from the product design to the delivery of the final product, by going through all the intermediate phases (specification definition, engineering, production and hardware testing, firmware development). The internal production department, optimized for prototypes and small series production, completes the offer towards customers.

Our commitment is to create simple and flexible products in order to help You better manager your heating and cooling systems.

SETECNA
Elettronica Per il Comfort



> Index

SOLUTIONS OVERVIEW	page 4
Sistema REG	page 5
Regulation Hydraulic schemes	page 6
REG System I/O Modules	page 8
REG System Bus Sensors	page 9
REG System Probes	page 10
REG System Display	page 11
REG System Gateway	page 12
Microreg	page 14
Modbus	page 15
Modbus sensors	page 16
Gateway Modbus-to-OpenTherm	page 17
Passive Ambient Temperature Probes	page 18
OEM Products	page 20
DOT	page 20
CLOUD	page 24
AVAILABLE CIVIL SERIES	page 26

> Icons Legend



MODBUS



Heat Pump

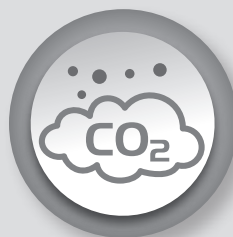

VOC



OpenTherm



CMV



BUS REG

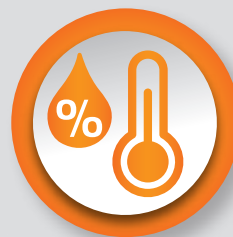

Temperature and humidity



Wi-Fi



Temperature



Konnex



Remote Control s5a.eu

➤ Solutions Overview

*Our solutions
in 5 points.*

**MADE IN
ITALY**

SETECNA
Elettronica Per il Comfort



> REG SYSTEM

Is a thermoregulation system for heating, cooling and domestic hot water production systems. It can be used for the distribution part control or for the heating/cooling power station management or for both! In the first case, it can manage heating and cooling radiant floor/ceiling systems including the dehumidifiers, it can prevent condensation thanks to the internal dew point calculation algorithm. It can also manage fan coil and radiator systems, mechanical ventilation and integration units both through dry contacts and via Modbus, using dedicated firmware. In the second case the REG System can manage heating and cooling generators (boilers, heat pumps, pellet stoves, thermal fireplaces, etc.) through dry contacts, 0/10 V set point, OpenTherm or Modbus RTU protocol. The REG System can be managed both through BMS (Modbus RTU or TCP/IP and KNX) and through our remote management system via Wi-Fi, LAN or GSM.

> MODBUS

It is a consolidated and widespread protocol in the thermoregulation field. Setecna EPC provides products such as temperature and humidity sensors and gateways Modbus-to-OpenTherm to manage heat generators. These products can be used by home automation systems designers and builders as building blocks of HVAC systems that use Modbus as main protocol.

> PASSIVE AMBIENT TEMPERATURE PROBE

Thanks to the know-how acquired in the Modbus and REG sensors production, Setecna EPC can produce Passive indoor ambient Temperature Probes for coordinated installation with the main flush-mounted civil series: BTicino (International, Living Light, Living NOW, Matix, Axolute); Vimar (Plana, Idea, Ekon, Arké); Gewiss (System, Chorus); ABB (Mylos, Chiara); Legrand Vela; AVE (Life, Domus, Tekla, Allumia); URMET Nea; JUNG LS squared and many more!

> OEM PRODUCTS

OEM (Original Equipment Manufacturer) products are tailor-made products based on our customers' specifications, which can be customized both in the hardware and in the firmware part. As Setecna EPC is a company with complete technical know-how, it is possible to follow the customer from the product design to the delivery of the final product, by going through all the intermediate phases (specification definition, engineering, production and hardware testing, firmware development).

> DOT

The DOT touch screen display is a simple and intuitive Smart Thermostat with 4.3" color TFT display for interaction with an HVAC system that combines the REG System flexibility with specific customer requirements! In its most complete version, DOT integrates on board a temperature and humidity sensor, an analogic / digital contact, an OpenTherm bus, a Modbus bus, a REG bus, a Wi-Fi Module and a mini USB type B 2.0 port. DOT can be supplied with different hardware configurations and with a completely customizable firmware that allows the HVAC system total supervision and its remote control via Web and mobile app.

➤ REG System

The REG System is ideal for the radiant system control and for HVAC systems Management

The REG System main features are:

- > easy to install and configure
- > elegant design components perfectly integrated with the main civil series
- > modular and complete functionalities
- > possibility to be integrated with home automation systems and BMS (Konnex, Modbus)

The REG System can manage:

- > up to **32 zones**
- > up to **8 independent weekly timer**
- > up to **8 distribution manifolds, also in cascade**, or **8 direct and/or mix circuits** (with mixing valves both with 3-points and 0/10V control)
- > both single and twin circulation pumps and their block signal (failover included)
- > up to **8 dehumidification, integration and renewal units**
- > up to **3 generators via dry contact or 0/10V** (Boilers, Heat Pumps, Fireplaces, etc.)
- > up to **8 generators via OpenTherm protocol** (with specific interface) or **Modbus RTU** (with specific interface with dedicated firmware) through cascade algorithms
- > **Domestic Hot Water production**
- > the **DHW recirculation pump** also through a dedicated clock
- > the **solar thermal circuit**
- > the **dew point control through sensors for cooling radiant system and internal algorithms**
- > different generators based on the external temperature, for systems with mixed generators (**Heat Pumps and Boilers**)

> electrical energy meters

- > a dry contact from the **Photovoltaic system**
- > up to 8 free analogic probes, 8 free digital inputs and 5 alarm signals (these signals do not affect the regulation, but they are only for control/monitoring).

REG System Main Advantages:

- > the Ambient Temperature and Humidity Sensors are perfectly integrated with the most common flush-mounted civil series design (BTicino, Vimar, Gewiss, ABB, ...)
- > the innovative sensors with LED display combine an elegant design with high functionality for all use conditions
- > simple and fast installation, easy configuration and commissioning thanks to the **built-in display** and **free configuration software**
- > the modular structure via Bus allows to optimize connections, reducing the cables number and installation costs
- > the system is equipped with dozens of presets, suitable for most systems.

An ecosystem of products and services to simplify installation and use:

- > can be **Remotely managed** via PC, Smartphone or Tablet (go to the remote management portal www.s5a.eu)
- > the configuration software **automatically generates the wiring diagrams** to simplify installation operation and reduce errors.

REG System



Regulation Hydraulic scheme

Example 1: Radiant System for Heating and Cooling of 4 Zones with Dehumidifier and Heat Pump

In this example, the REG System manages a radiant heating and cooling system with one dehumidifier and a heat pump, in detail the Reg manages the following components:

- > 4 zones (kitchen/living room, bathroom, bedroom 1 and 2);
- > a dehumidifier;
- > an electric towel warmer;
- > a direct circuit;
- > a buffer tank;
- > an external temperature probe
- > a heat pump (set point via 0 / 10V, ON / OFF and heat/cool switch via dry contact, alarm signal input).

In addition, the REG-DOT-B display touch screen temperature and humidity sensor is used for the living room, which allows you to manage the system remotely via Wi-Fi.

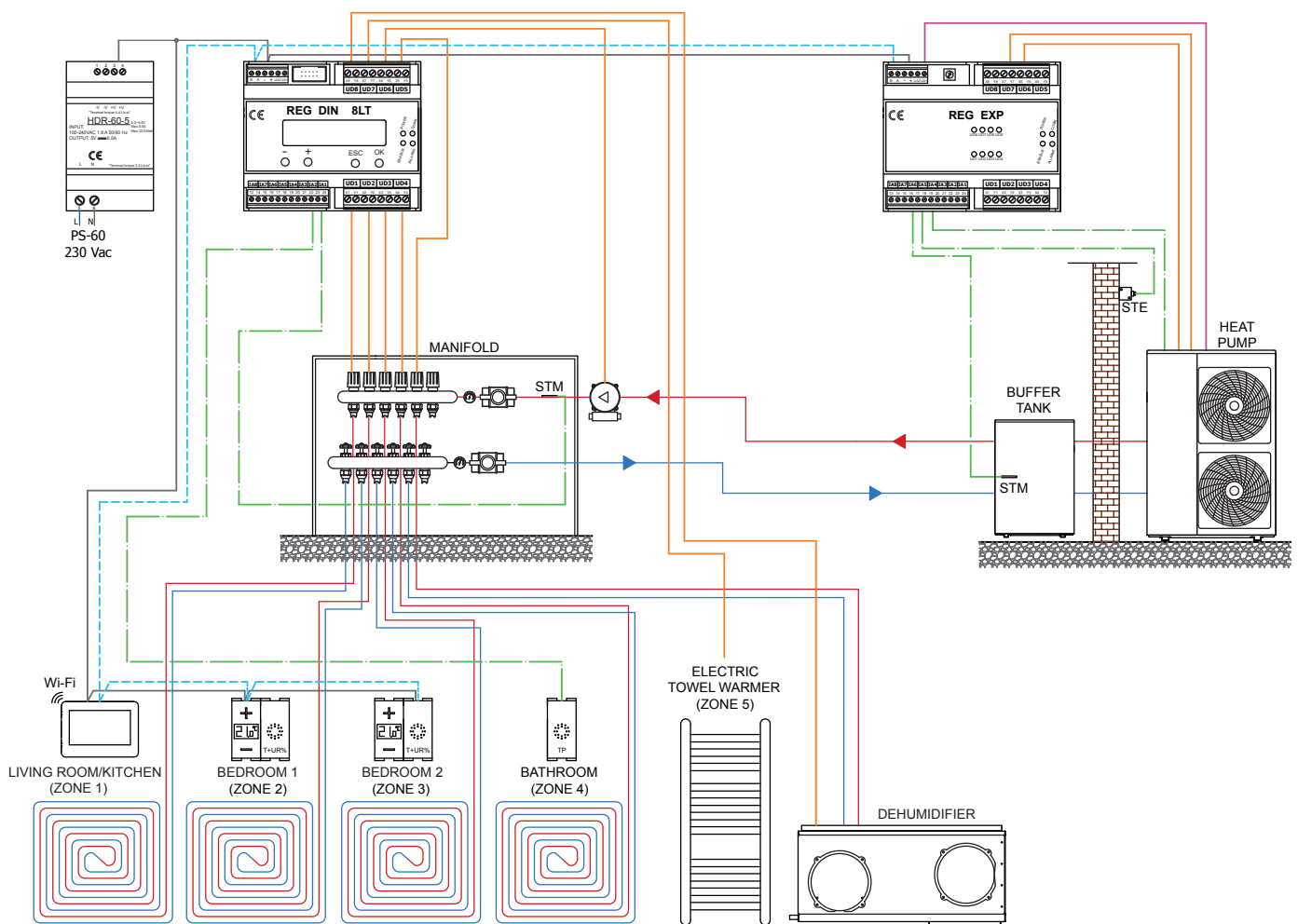

LEGEND

- Digital output
- Analogical output (0/10V)
- Analogical/Digital output
- Bus Reg connection
- Power supply 12 Vdc

- PS60** Power supply 60W
- REG-DIN-8** Master Regulator
- REG-EXP-8** Expansion I/O
- STM** Water temperature probe
- STE** External temperature probe
- REG-THL** TH sensor with display
- TP** Ambient temperature probe
- REG-DOT-B** Display Touch Screen

Regulation Hydraulic scheme

Example 2: Home Heating and Cooling Power Plant with Boiler and Heat Pumps

In this example, the REG System manages a home heating and cooling power plant consisting of two heat pumps and a boiler, in detail the Reg manages the following components:

- > two heat pumps via Modbus (with dedicated firmware) both for heating and cooling and one for domestic hot water production;
- > a boiler via OpenTherm to support heating in winter and to support DHW production
- > a buffer tank;
- > an external temperature probe;
- > a DHW storage tank and its recirculation pump;
- > two mixed and one direct circuits.

The GSM module is used to control the system remotely.

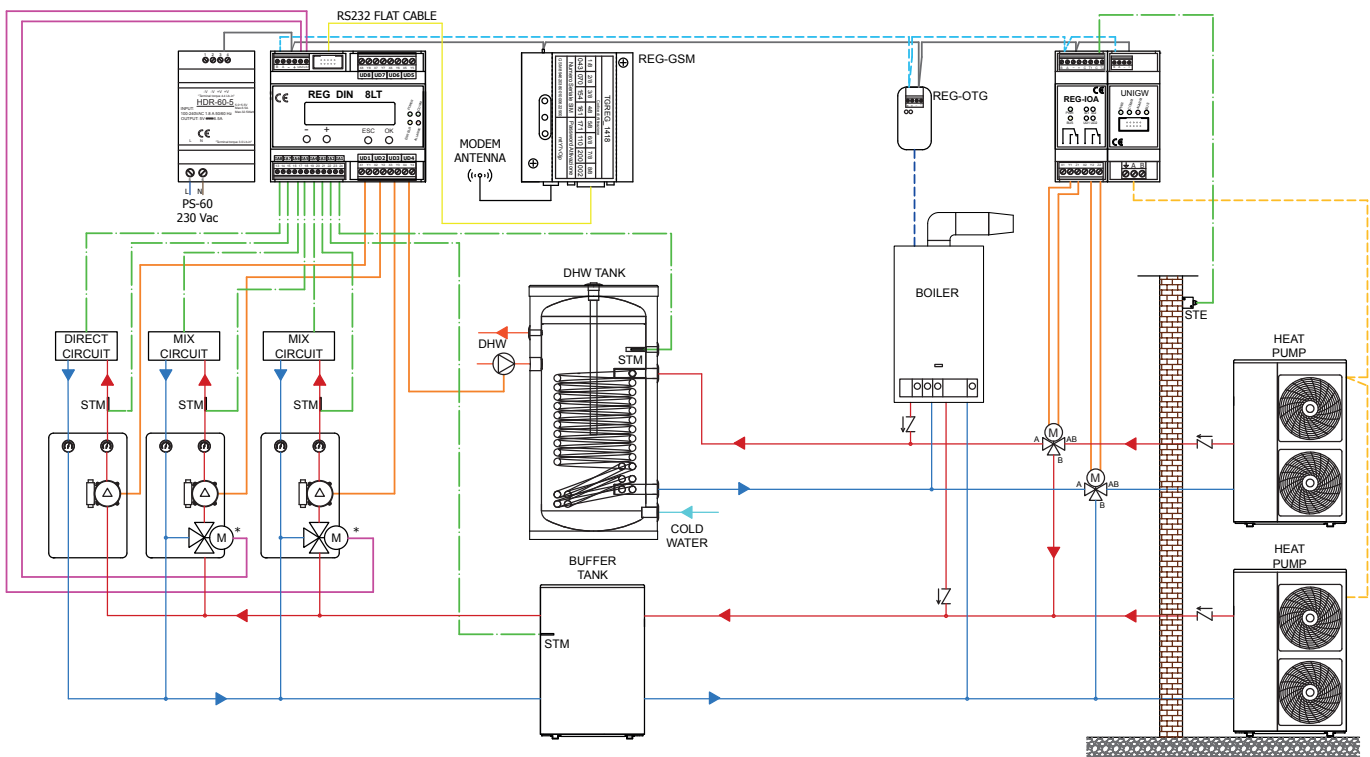

LEGENDA

- Digital output
- Analogical output (0/10V)
- Analogical/digital input
- Bus Reg connection
- Power supply 12 Vdc
- Connection via OpenTherm
- Connection via Modbus RTU

- PS60** Power supply 60W
- REG-DIN-8** Master Regulator
- REG-IOA** Expansion I/O
- STM** Water temperature probe
- STE** External temperature probe
- REG-OTG** OpenTherm gateway
- REG-UGW-485** RS485 gateway
- REG-GSM** GPRS/GSM module

* 24 Vac converter for the mixing valves third party supplied

➤ REG System and I/O Expansion modules

The flexibility and modularity of the REG System is guaranteed by the available I/O Expansion modules. The REG Master (REG-DIN-8) I/O Modules can be amplified with the REG-EXP-8 module that has the same number of I/O [up to 7 REG-EXP-8 can be installed on each system] or with smaller I/O modules that adapt to every need: it is possible to install up to 36 REG-IOA, 12 REG-IOB and 8 REG-IOC for each system.



REG-DIN-8

REG System master Regulator (8 IA/ID - 8 UD - 2 UA):

8 digital outputs, 2 analogue outputs and 8 inputs (analogue or digital)

The controller is set up for mounting in the electrical panel, on a standard DIN rail (6 modules), the connection with components to be checked in the system (sensors, expansions, I/O and UGW modules) is through the proprietary bus.



REG-EXP-8

I/O expansion module of the REG System (8 IA/ID - 8 UD - 2 UA):

8 digital outputs, 2 analogue outputs and 8 inputs (analogue or digital)

The REG-EXP-8 expansion module is set up for mounting in the electrical panel, on standard DIN rail (6 modules), and the connection with the REG System is through the proprietary bus.



REG-IOA

I/O expansion module of the REG System (2 IA/ID - 2 UD):

2 digital outputs and 2 inputs (analogue or digital)

REG-IOA is a I/O expansion module of the REG System comprised of 2 digital outputs and 2 inputs (digital or analogue based on programming) set up for mounting in electrical panel, on standard DIN rail (2 modules). The connection to the regulation system is with bus.



REG-IOB

I/O expansion module of the REG system (2 IA/ID - 1 UD - 1 UA):

1 analogue output, 1 digital output and 2 inputs (analogue or digital)

REG-IOB is a I/O expansion module of the REG System comprised of 1 analogue output and 1 digital output and 2 inputs (digital or analogue based on programming) set up for mounting in electrical panel, on standard DIN rail (2 modules). The connection to the regulation system is with bus.



REG-IOC

I/O expansion module of the REG system (2 IA/ID - 2 UA):

2 analogue outputs and 2 inputs (analogue or digital)

REG-IOC is a I/O expansion module of the REG System comprised of 2 analogue outputs and 2 inputs (digital or analogue based on programming) set up for mounting in electrical panel, on standard DIN rail (2 modules). The connection to the regulation system is with bus.

➤ REG System Sensors

In a building the REG System can individually manage up to 32 zones using active microprocessor ambient temperature and humidity sensors with or without LED display or passive ambient temperature probes. Plus, with the REG-AQ sensor it is possible to control the indoor air quality and enable or disable the renewal unit, if installed.



REG-THL

Temperature and relative humidity sensors with LED display for REG System (flush-mounted)

REG-THL sensors are active with microprocessor to measure the temperature and relative humidity provided for installation with coordinated design with the main flush-mounted civil series (BTicino, Vimar, Gewiss, ABB etc.) featuring LED display to view and set parameters.

The connection with the REG regulation system is through proprietary bus and the sensor is powered with 12 Vdc. Inside, normal 503 boxes they occupy two positions (one for the sensor and one for the display).



REG-TH

Temperature and relative humidity sensors for REG System (flush-mounted)

REG-THL sensors are active with microprocessor to measure the temperature and relative humidity provided for installation with coordinated design with the main flush-mounted civil series (BTicino, Vimar, Gewiss, ABB etc.). The resolution of the temperature and relative humidity measurement is respectively 0.1°C and 0.1% RH. The sensor is powered with 12 Vdc and the connection with the REG regulation system is through bus.

Inside, normal 503 boxes they occupy one position.



REG-AQ

Indoor air quality sensor for REG System (flush-mounted)

REG-AQ sensors are active with microprocessor to measure the CO₂ quantity and the volatile compounds (VOC) found in the air, provided for installation with coordinated design with the main flush-mounted civil series (BTicino, Vimar, Gewiss, ABB etc.). The sensor is powered with 12 Vdc.

The connection to the REG regulation system is with bus. Inside, normal 503 boxes they occupy one position.



TP

Passive ambient temperature probes - NTC 12 K (flush-mounted)

The TP probes are passive ambient temperature probes provided for installation with coordinated design with the main flush-mounted civil series (BTicino, Vimar, Gewiss, ABB etc.). The sensitive element is a NTC thermistor, 12K@25°C with B3977, with 2-pole terminal.

Inside, normal 503 boxes they occupy one position.

> REG System Probes

It is also possible to connect various types of temperature probes to the REG System that allow full management of the system: water temperature probes (for DHW tanks, buffer tanks or for pipes) such as the well STM or the strap STB, external temperature probe (STE) or high temperature probe for thermal solar system such as STA.



STM

Well water temperature probe with NTC 12 K sensor

The STM probe is a temperature probe to measure the water temperature of the circuits. The sensitive element is a NTC thermistor, 12K@25°C with beta 3977 inserted in a brass pipe. The probe is equipped with a 2-metre silicone cable. The relative stainless steel PSTM well is also available.

It is compatible for installation with the REG System on analogue input (REG-DIN-8, REG-EXP-8, REG-IOA, REG-IOB, REG-IOC).



STB

Strap water temperature probe with NTC 12 K sensor

The STB probe is a passive strap temperature probe to measure the temperature of pipes. The sensitive element is a NTC thermistor, 12K@25°C with beta 3977. The probe is equipped with an already integrated rubber strap and a separate additional strap. The cable is 2 metres long.

It is compatible for installation with the REG System on analogue input (REG-DIN-8, REG-EXP-8, REG-IOA, REG-IOB, REG-IOC).



STA

High Temperature Probe - NTC 10 K B3970

The STA probe is a temperature probe to measure the water temperature of solar circuits. The sensitive element is a NTC thermistor, 10K@25°C with beta 3970 inserted in a stainless steel pipe. The probe is equipped with a 2-metre teflon cable. It is compatible for installation with the REG System on analogue input (REG-DIN-8, REG-EXP-8, REG-IOA, REG-IOB, REG-IOC).



STE

Outdoor passive temperature probe with NTC 12 K sensor

The STE probe is a passive ambient temperature probe for outdoors. The sensitive element is a NTC thermistor, 12K@25°C with beta 3977, with 2-pole terminal. The probe is equipped with integrated cable gland for cable with diameter between 5 and 10 mm. It is compatible for installation with the REG System on analogue input (REG-DIN-8, REG-EXP-8, REG-IOA, REG-IOB, REG-IOC).

> REG System Display

The REG System can manage up to 2 touch screen displays for each system, to make it user friendly! They do not require any specific setting, as they acquire the one of the REG-DIN-8 that they are connected to. Two displays are available:



REG-TFT

2.4" Colour Touch Screen Display

The Touch screen display is used as a user friendly interface to control the REG-DIN-8 regulator. The display has the possibility of being flush-mounted in coordination with the main civil series (Bticino, Gewiss, Vimar, ABB, AVE, etc.) which allows perfect integration with the design of the house.

It can be installed in normal 503 boxes and powered with 12 Vdc.

From the display the user can set weekly programming of the clocks, if present, the ambient temperature set points, system activation and seasonal change (if the system is for cooling and heating).

It does not require any type of programming as the pages automatically adapt to the system structure, once the display is enabled from the REG-DIN-8.

If you choose the BTicino Living Now series, the code is **REG-TFT-NOW**.



REG-DOT-B

4.3" Colour Touch Screen Display with integrated temperature and humidity sensor and on-board Wifi interface

REG-DOT-B is a colour touch screen display used as a user friendly interface to control the REG-DIN-8 regulator. The display is equipped with a temperature and humidity sensor and Wi-Fi interface for the remote connection from the remote management portal. It does not require any type of programming as the pages automatically adapt to the system structure, once the display is enabled from the REG-DIN-8.

From the display the user can set the weekly programming of the clocks, if present, the ambient temperature and humidity set points, system activation and DHW production, seasonal change and access to the user and advanced settings menus (it is possible to protect them with passwords).

The cover of the display can be removed and allows access to a type B mini USB port that allows the connection with a PC.



> REG System Gateway/Interfaces

The REG System has a very broad and complete connectivity. It can be connected to BMS systems that use Modbus protocol (both RTU and TCP/IP) or Home Automation systems through gateway KNX. Lastly, it is possible to remotely manage the system through cloud (either via Web or via App) installing the available LAN or GSM modules.



REG-KNX

Gateway for interfacing the REG System with home automation KNX

It is set up for mounting in electrical panel, on standard DIN rail (4 modules). The supervision system that the gateway is connected to must have KNX protocol (kon-nex). The connection part to the KNX bus is implemented through a certified communication module. The REG-KNX gateway provides 250 datapoints, which are freely configurable by who configures the KNX home automation system.



REG-MBS-ETH

Interface for Modbus over TCP/IP System supervision

The supervision interface of a ModBus over TCP/IP system is set up for mounting in electrical panel box, on standard DIN rail (2 modules). The supervision system that the interface is connected to must have ModBus TCP/IP protocol. When it is delivered the module has pre-set address 192.168.127.254, to change it, refer to the complete manual.



REG-MBS-RTU

Interface for Modbus over 485 System supervision (RTU protocol)

The supervision interface of a ModBus over 485 system (RTU protocol) is set up for mounting in electrical panel box, on standard DIN rail (2 modules). The supervision system that the interface is connected to must have ModBus RTU (RS-485) protocol. The interface allows a third party supervision system to modify and read the parameters of the REG system, which is seen as a slave device.



REG-GSM

Remote Control Module for the REG system in GSM/GPRS technology

The module for the REG system connection to the remote control website is set up for mounting in electrical panel box, on standard DIN rail (4 modules). The module already includes a data SIM pre-activated for 4 months and comes complete with the serial cable for the connection of the module to the regulator, the magnetic antenna, the power supply cable and the information leaflet with the name assigned to the system (example TGREG_1587), the identification code (8 digits) and the password.



REG-LAN-MK2

Remote Control Module for the REG system in Ethernet / LAN technology

The module for the REG system connection to the remote control website is set up for mounting in electrical panel box, on standard DIN rail (2 modules) and is set up to be connected to the network through Ethernet / LAN cable (not supplied). The module comes complete with the serial cable for the connection of the module to the regulator and the information leaflet with the name assigned to the system (example TGREG_1587), the identification code (8 digits) and the password.

> REG System Gateway/Interfaces

The REG System can control RS485 Modbus RTU units through REG-UGW-485 with dedicated firmware such as heat pumps, renewal, dehumidification and integration units and energy meters. While it is possible to manage through OpenTherm by installing up to 8 REG-OTG (one for each generator) or up to 2 REG-OT4 (one every 4 generators) boilers or other sources of heat that support this protocol (the firmware is universal).



REG-UGW-485

Universal Module for RS485 Modbus RTU units controlled by the REG System

The universal module is set up for mounting in the electrical panel box, on standard DIN rail (2 modules), and the connection with the REG regulation system is via bus. Through the RS485 output it is possible to control RS485 Modbus RTU units such as for example Heat Pumps, Boilers, Dehumidification, Integration and Renewal units, energy meters. Communication is possible through the implementation of a dedicated firmware uploaded on the universal module through port RS232. All connections are set up through removable terminals and the module is equipped with LEDs to indicate status. There is a 16-position switch to select the module address.



REG-OT4

4-channel OpenTherm Gateway for REG System

The 4-channel OpenTherm Gateway is set up for mounting in the electrical panel box, on standard DIN rail (2 modules), and the connection with the regulation system is through the proprietary bus. The gateway is set up with 4 channels for communication through OpenTherm protocol with the same number of generators. All connections are set up with removable terminals, that make installation easier. The module is equipped with LEDs for status indication. There are two 16-position switch to select the module address. At most two REG-OT4 can be connected to each REG system.



REG-OTG

1-channel OpenTherm Gateway for REG System

The 1-channel OpenTherm gateway can be installed in the electrical panel box or inside the generator chassis that communicates with, the connection with the regulation system is through the proprietary bus. The gateway is set up with 1 channel for communication through OpenTherm protocol with only one heat generator. All connections are set up with removable terminals, that make installation easier. The module is equipped with LEDs for status indication. Inside the module there is a 16-position switch to select the address (from 1 to 8). The REG system can manage up to eight REG-OTG.

➤ MICROREG

Master stand-alone regulator

The **MICROREG** controller is available in two versions:

- > **MICROREG-C** for a one mix circuit management
- > **MICROREG-Z** for 5 zones (maximum) management.

The **MICROREG-C** regulator is designed to be installed in systems where existing ambient thermostats manage the radiant system (radiant head control on the manifolds), while the MICROREG-C:

- > manages the condensation with radiant cooling systems, including the demand to the dehumidifier, if installed (in this case it is necessary to install a REG-TH temperature and humidity sensor connected by proprietary bus to the MICROREG-C);
- > manages an integration unit to the radiant system in both heating and cooling, if a REG-TH temperature and humidity sensor is installed;
- > controls, if there is a mixed circuit, the water pump, the mixing valve and the water temperature probe;
- > sends the energy demand to the generator for both heating and cooling.

The **MICROREG-Z** regulator can manage up to 5 zones with ambient sensor and the thermal actuator heads, a water pump (and mixing valve with 0/10V control if installed) or an energy demand to a generator for both heating and cooling and a dehumidifier. If used to manage 4 zones instead of 5, it can also manage an integration unit.



Also in this version it can manage condensation in radiant cooling systems, including demand to the dehumidifier if installed.

In both cases the controller is equipped with a second BUS connection for "centralised" operation: through a two-wire proprietary bus connection, multiple MICROREG regulators can use a single external probe and receive activation commands from the controller of the thermal power station (on/off, summer/winter switching, etc.). Alternatively the regulator is equipped with Modbus RTU interface that allows a third party BMS system inside a residential buildings with many flats to manage multiple MICROREGs from a single web station with a customized setting.

SETECNA
Elettronica Per il Comfort



➤ MODBUS

Indoor Ambient Sensors and Gateway-to-OpenTherm

SETECNA EPC realized two product lines with Modbus RTU protocol:

- > **Flush-mounting microprocessor sensors for ambient temperature and humidity measurement.**
- > **Modbus to OpenTherm Gateway for heat generators management.**

The Temperature and Humidity Sensors are made directly on the modular components of the main flush-mounted civil series (BTicino, ABB, Gewiss, Vimar, AVE, etc.): they integrate perfectly with any customer aesthetic choice; the high visibility LED display and the touch technology buttons allow to add elegance and functionality to the Sensors.

The sensors are available in 2 versions:

- > Ambient Temperature and Humidity Sensor without display.
- > Ambient Temperature and Humidity Sensor with LED display and Touch Interface.

In particular, the versions with LED display and Touch Interface allow to:

- > view the ambient temperature and the humidity (% RH)
- > view an "Active System" indicator
- > view and modify the Room Temperature setpoint
- > view and modify the work mode of the room (ON/OFF/AUTO).

The "Active System", "SetPoint" and "Work Mode" functions can be controlled by the MODBUS Master, which can enable or disable them and set the values.

All sensors are compatible with the Modbus RTU protocol and both versions are available with both 19200 and 9600 baud rate; other configurations can be supplied on request.

Modbus to OpenTherm gateways allow a Modbus RTU Master system to manage heat generators as an OpenTherm Master.

The gateways available are with 1 channel or 4 channels.

The gateways provides both in read- and write-mode all the parameters defined by the OpenTherm protocol: it is possible to read the sensors and the errors, to change the set point and the working mode of the generator (heating or DHW production).

Also for the Gateways, by simply modifying the Dip Switch present below the cover, it is possible to set the baud rate (19200 or 9600) and the parity (NONE or EVEN).



> MODBUS sensors

Flush-mounted microprocessor sensors for measuring ambient temperature and humidity; they are built directly on the modular components of the main flush-mounted civil series (BTicino, ABB, Gewiss, Vimar, AVE, etc.). They are available with or without display and with baud rate 9600 or 19200.

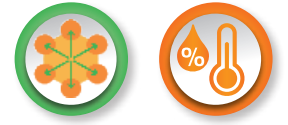

MB-THL

Active MB-THL temperature and humidity sensors with LED display - baud rate 19200

MB-THL sensors are active sensors with microprocessor to measure the temperature and relative humidity provided for installation with coordinated design with the main flush-mounted civil series (BTicino, Vimar, Gewiss, ABB etc.) featuring high readability LED display to view and set parameters. Using two touch buttons through the Modbus RTU (RS485) it is possible to set the temperature set point and the system operating mode (ON, OFF, Auto). The sensors have the following characteristics:

- > the resolution of the temperature measurement is 0.1°C, the typical accuracy is +/- 0.4°C;
- > the resolution of the humidity measurement is 0.1% RH, the typical accuracy is +/- 3%RH;
- > the communication parameters are 19200, N, 8, 1;
- > the configurable slave address goes from 1 to 255.

Inside the 503 box they occupy 2 positions.

Also available in the 9600 baud rate version (MB-THL-9K6).



MB-TH

Active MB-TH temperature and humidity sensors - baud rate 19200

MB-TH sensors are active sensors with microprocessor to measure the temperature and relative humidity provided for installation with coordinated design with the main flush-mounted civil series (BTicino, Vimar, Gewiss, ABB etc.). The sensors have the following characteristics:

- > the resolution of the temperature measurement is 0.1°C, the typical accuracy is +/- 0.4°C;
- > the resolution of the humidity measurement is 0.1% RH, the typical accuracy is +/- 3%RH;
- > the communication parameters are 19200, N, 8, 1;
- > the configurable slave address goes from 1 to 255.

Inside the 503 box they occupy 1 position.

Also available in the 9600 baud rate version (MB-TH-9K6).

➤ MODBUS-to-OpenTherm Gateway

The Modbus to OpenTherm gateways allow a Master Modbus RTU system to manage heat generators as Master OpenTherm. The available gateways have 1 (MB-OTG) or 4 (MB-OT4) channels. The gateways place all of the parameters defined by the OpenTherm protocol at disposal in either read or write mode: from reading probes to errors, from set point to generator operating mode setting. Through a simple modification of the dip switch installed on the module, it is possible to set baud rate (19200 or 9600) and parity (EVEN or NONE).



MB-OTG

1-Channel Modbus-to-OpenTherm Gateway

The 1-channel ModBus - OpenTherm gateway can be installed in the electrical panel box or inside the generator chassis that communicates with is powered with 12 Vdc. The supervision system that the gateway is connected to must have Modbus RTU protocol (RS-485) with settable communication parameters (baud rate 9600 or 19200, parity even or none).

The configurable slave address goes from 16 to 23.

The gateway is set up with 1 channel for communication through OpenTherm protocol with only one heat generator. All of the connections can be set up using removable terminals; plus, the connection is opto-isolated towards the generator.



MB-OT4

4-Channel Modbus-to-OpenTherm Gateway

The 4-channel ModBus - OpenTherm gateway is set up for mounting in the electrical panel box, on standard DIN rail (2 modules), and the power supply is 12 Vdc. The regulating system that the gateway is connected to must have Modbus RTU protocol (RS-485) with settable communication parameters (baud rate 9600 or 19200, parity even or none).

The slave address must be configured between 1 and 63.

The gateway is set up with 4 channels for communication through OpenTherm protocol with the same number of generators. All of the connections can be set up using removable terminals; plus, the connection is opto-isolated towards the generators.

▶ Passive Temperature Probes

Thanks to the know-how and production processes developed for the REG and Modbus microprocessor sensors, we can realize Passive indoor ambient Temperature Probes for coordinated installation with the main flush-mounted civil series available on the market (BTicino, ABB, Vimar, Gewiss etc.).

It is also possible to order probes with various type thermistors:

- > PT 1000
- > PT 100
- > NTC 10 K beta 3435
- > NTC 10 K beta 3980
- > NTC 12 K beta 3977
- > Other types available on request

The probes occupy only one position in the normal flush-mounted boxes 503.

**The above Brands are registered trademarks owned by their respective Companies.*

SETECNA
Elettronica Per il Comfort



> Passive temperature probes

Setecna EPC can produce passive probes with various types of thermistors. As with Modbus or REG sensors, also passive probes can be produced in coordination with the main flush-mounted civil series available on the market.



TP-PT1K

Passive ambient temperature probes (flush-mounted) – PT1000

The TP-PT1K probes are passive ambient temperature probes provided for installation with coordinated design with the main flush-mounted civil series (BTicino, Vimar, Gewiss, ABB etc.).

The sensitive element is a PT1000, 1K@0°C thermistor with 2-pole terminal.

Inside the 503 box they occupy one position.

Not compatible with the REG System.



TP-PT100

Passive ambient temperature probes (flush-mounted) - PT100

The TP-PT100 probes are passive ambient temperature probes provided for installation with coordinated design with the main flush-mounted civil series (BTicino, Vimar, Gewiss, ABB etc.).

The sensitive element is a PT100, 1K@0°C thermistor with 2-pole terminal.

Inside the 503 box they occupy one position.

Not compatible with the REG System.



TP-10K

Passive ambient temperature probes (flush-mounted) – NTC 10 K B 3435

The TP-10K probes are passive ambient temperature probes provided for installation with coordinated design with the main flush-mounted civil series (BTicino, Vimar, Gewiss, ABB etc.). The sensitive element is a NTC thermistor, 10K@25°C with B3435, with 2-pole terminal.

Inside the 503 box they occupy one position.

Not compatible with the REG System.



TP-10K3980

Passive ambient temperature probes (flush-mounted) – NTC 10 K B3980

The TP-10K3980 probes are passive ambient temperature probes provided for installation with coordinated design with the main flush-mounted civil series (BTicino, Vimar, Gewiss, ABB etc.). The sensitive element is a NTC thermistor, 10K@25°C with B3980, with 2-pole terminal.

Inside the 503 box they occupy one position.

Not compatible with the REG System.



TP-12K3977

Passive ambient temperature probes (flush-mounted) - NTC 12 K B 3977

The TP probes are passive ambient temperature probes provided for installation with coordinated design with the main flush-mounted civil series (BTicino, Vimar, Gewiss, ABB etc.). The sensitive element is a NTC thermistor, 12K@25°C with B3977, with 2-pole terminal.

Inside the 503 box they occupy one position.

Compatible with the REG System.



➤ OEM Products

Setecna EPC designs and builds customized boards for OEM customers.

Starting from the analysis of functional needs, Setecna is able to propose customized solutions, both in the hardware and software components. The internal production line, optimized to be as flexible as possible, can carry out sampling, pre-series and production series even in small quantities.

The firmware on the PCB boards can, depending on the customers' needs, be made from scratch or derived from other Setecna products, such as the REG System.

In this case, the custom product can immediately exploit all the capabilities of the REG System such as expansion modules (I/O modules), programming software, the remote management system, thus allowing you to have a customized system in a short time and with limited investments, but at the same time a complete and functional one.

➤ DOT

DOT is a complete platform, based on an ARM Cortex M4 microprocessor and a 4.3" color TFT display, for the HVAC system control and supervision.

In its most complete version, DOT integrates on board:

- > a temperature and humidity sensor;
- > an air-quality sensor;
- > an analogic / digital input contact;
- > an OpenTherm bus for the managements of boilers that support this protocol;
- > a Modbus bus for the management of heat pumps for heating and cooling and for the domestic hot water production, for the management of ventilation, integration and/or dehumidification units and energy meters with dedicated firmware;
- > a REG bus for the management of the REG System I/O modules (REG-IOA, REG-IOB, REG-IOC, REG-EXP-8), of the temperature/humidity sensors via bus (REG-TH and REG-THL) and air-quality sensors via bus (REG-AQ);
- > a Wi-Fi modem for connection to the www.s5a.eu remote system management;
- > a mini USB type B 2.0 port to connect via PC.



DOT can be supplied with different hardware configurations and with a completely customizable firmware that allows the total supervision of an HVAC system and its remote management via Web and mobile app.

DOT looks like an elegant display with a 480x272 pixels resolution framed in a rigid white plastic package. This display can be mounted on the wall in a domestic environment in order to be used as a thermostat or in the central heating/cooling station as a control panel.

The end user can interact with DOT via touch on the display or via remote control via Web or mobile app when the Wi-Fi modem on board is connected to Internet. The firmware can be updated via Wi-Fi or via USB using the USB port.

The DOT graphic interface is simple to use: the main functions are shown intuitively for the end user, while the additional configurations are available in advanced menus for the installer and the technical assistance.

Finally, there is the possibility of associating a QR code to each device through which the user can access to the manual or other technical documentation.



DOT FOR HEAT PUMPS MANAGEMENT VIA MODBUS RTU

DOT developed for heat pumps management allows you to manage the generator completely using Modbus RTU protocol, it is also possible to install it in the house and thanks to the included Temperature and Humidity sensor, adapt the temperature required to the heat pump even based on the outside temperature. The display has a Wi-Fi modem on board.

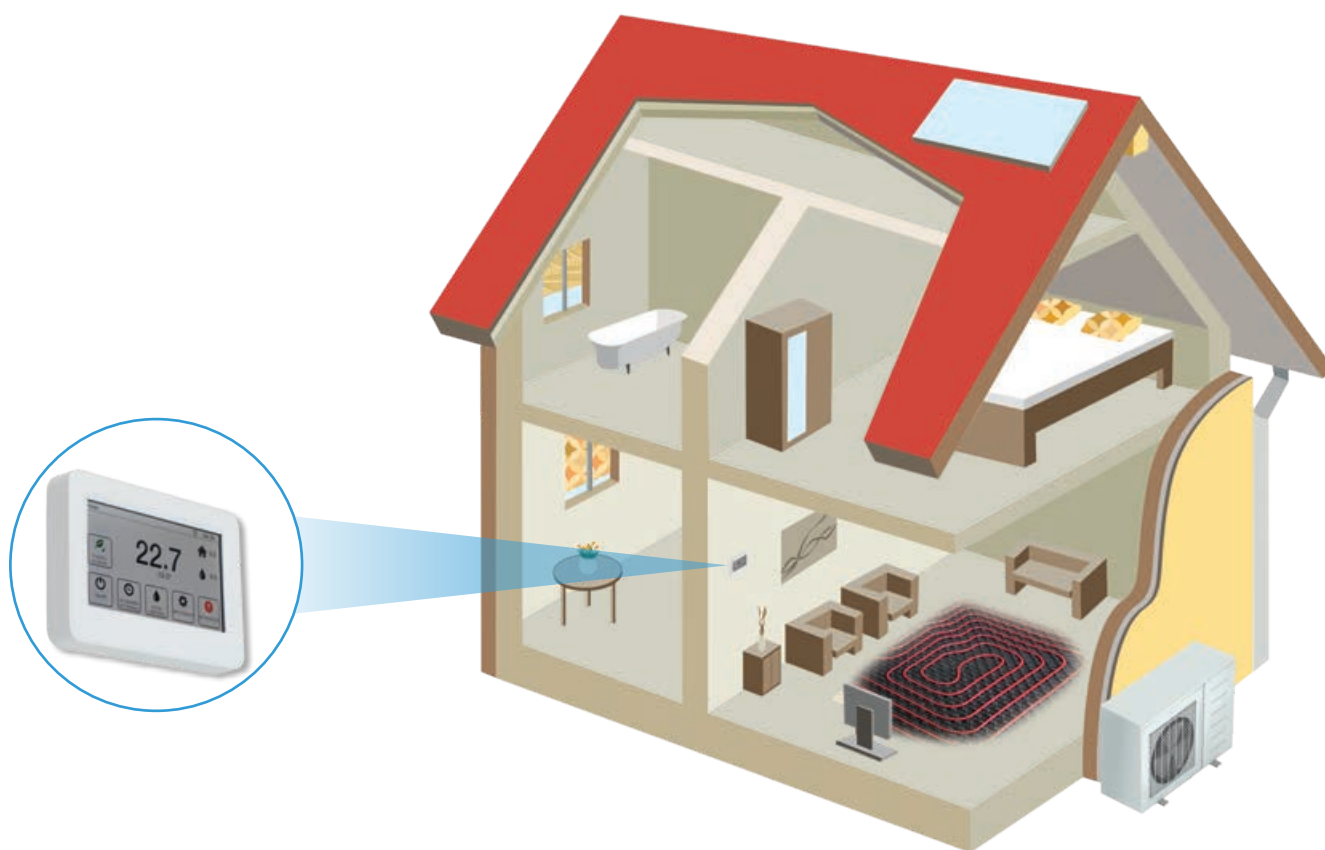

Here is a screenshot of DOT Home Page for Heat Pumps where it is possible to:

- > view the current season
- > view the external and domestic hot water temperatures if preset
- > set the working mode of the zone managed by the ambient temperature and humidity sensor (Comfort, Economy or OFF)
- > access the weekly program
- > access to the setting and information menus of the heat pump
- > view the alarms if preset.

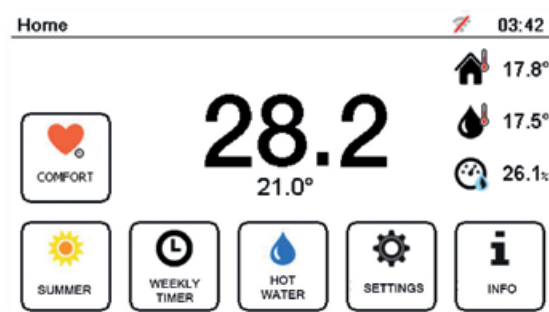

DOT FOR BOILERS MANAGEMENT VIA OPENTHERM

DOT developed for boilers management allows you to manage the generator completely using OpenTherm protocol, it is also possible to install it in the house and thanks to the included Temperature and Humidity sensor, adapt the temperature required to the boiler even based on the outside temperature. The display has a Wi-Fi modem on board.

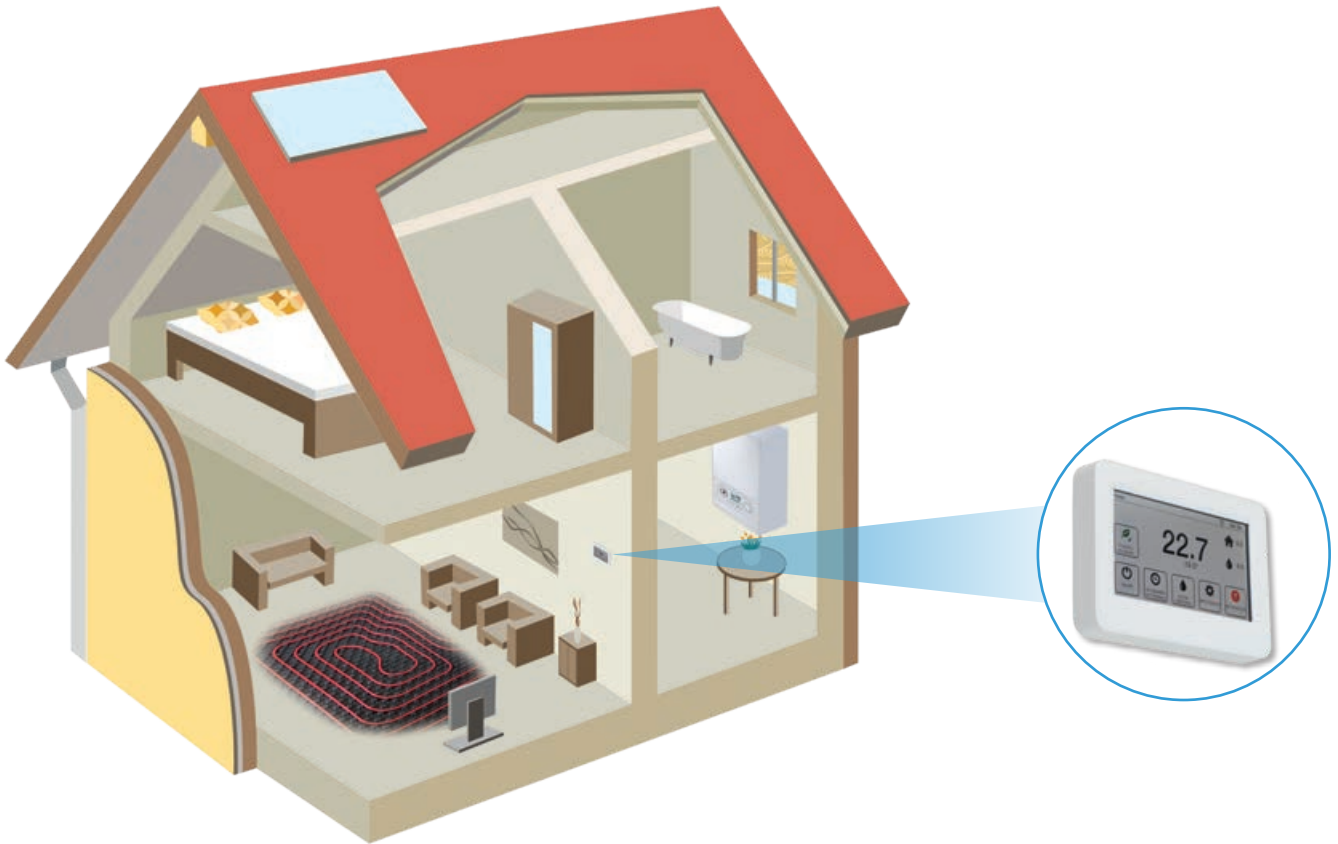

Here is a screenshot of DOT Home Page for Boilers where it is possible to:

- > view the current season
- > view the external and domestic hot water temperatures if preset
- > set the working mode of the zone managed by the ambient temperature and humidity sensor (Comfort, Economy or OFF)
- > access the weekly program
- > access to the setting and information menus of the boiler
- > view the alarms if preset.

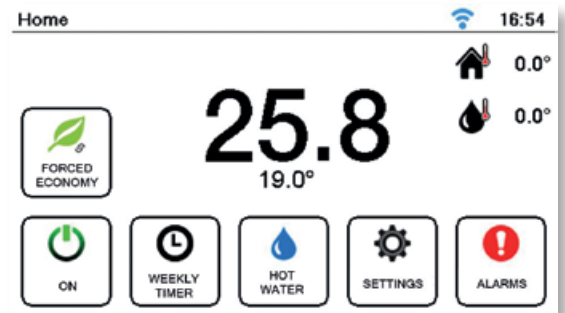

DOT AS REG SYSTEM DISPLAY

DOT developed as a user interface of the REG System allows you to manage the system in a simple and intuitive way. The REG-DOT-B has a temperature and humidity sensor and a Wi-Fi modem on board.

The REG-DOT-B is the display of the REG System, it does not require any specific program as it automatically acquires the set up on the REG-DIN-8 regulator, therefore only what has been programmed will be displayed.

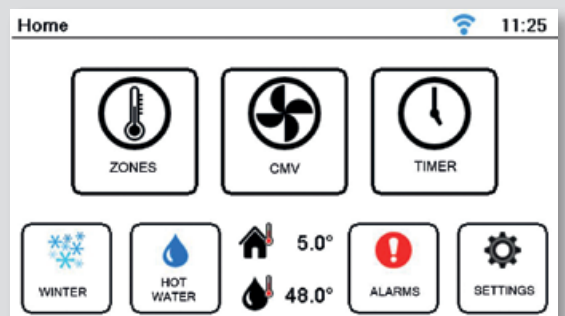

DOT FOR VENTILATION, DEHUMIDIFICATION AND INTEGRATION UNIT MANAGEMENT VIA MODBUS

The DOT developed for the management of a ventilation, integration and / or dehumidification unit allows you to manage the unit completely using the Modbus RTU protocol and dedicated firmware; the temperature, humidity and air quality sensors ensure optimal internal comfort even in the most insulated houses. The display has a Wi-Fi modem on board.

Here is a screenshot of DOT Home Page for a ventilation, integration and dehumidification unit where it is possible to view: > the current season and the outside temperature > if integration or dehumidification are active > the ambient air temperature and humidity (% RH) > ppm of CO₂ and ppb of VOC (Volatile Organic Compounds) > the fan speed and whether in automatic or manual mode > through the settings and information menu, it is possible to access submenu dedicated to the end user and technical assistance.

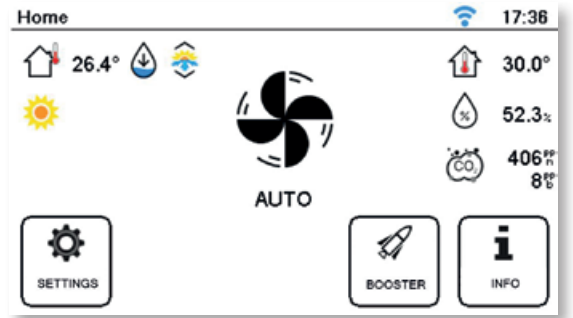

DOT FOR ALL

The complete DOT is full optional and includes the OpenTherm protocol, the Modbus RTU protocol, the REG bus, a temperature and humidity sensor, an air quality sensor and a WiFi modem. It becomes the controller of the entire system de facto and can exploit all the potential of the REG System.

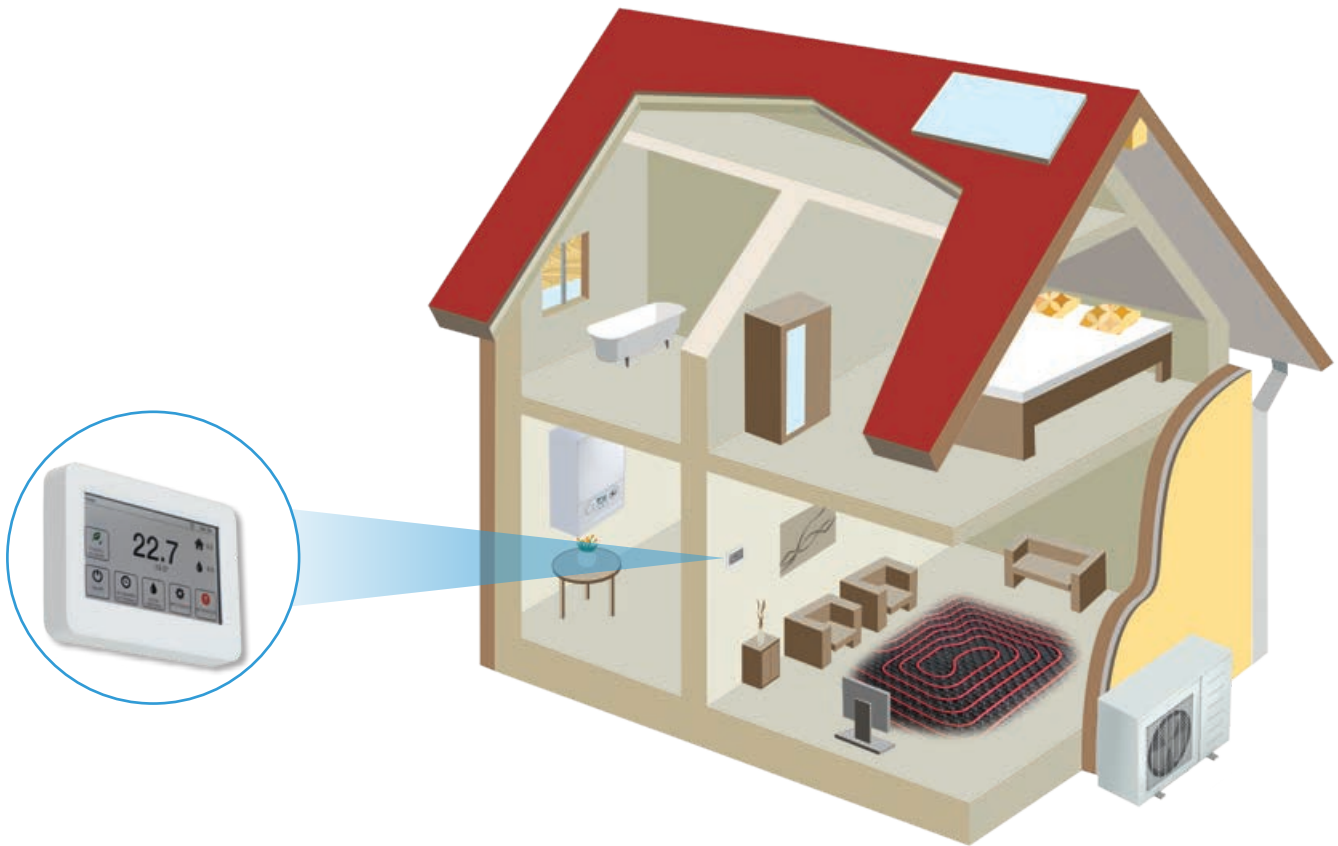

The Modbus RTU line can be connected to heat pumps or other generators, ventilation, dehumidification and integration units through the development of a dedicated firmware. The REG bus line allows you to connect all the REG System I/O modules and the other REG-TH, REG-THL or REG-AQ bus sensors. The OpenTherm line allows you to manage a generator that supports the protocol.

Here is a screenshot of the complete DOT which has two Home Pages: > one dedicated to the end user from where it is possible to manage the zones, clocks and CMV units; > the other one dedicated to the installer from where it is possible to change the set points of the circuits and view the status of the generators and diagnostic information.

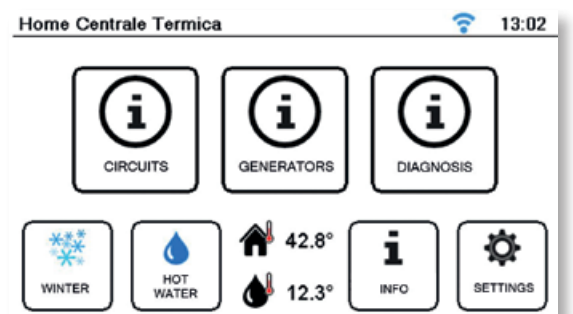

> Cloud

The REG system allows you to remotely manage the systems in a simple and effective way.

The Remote management system is mainly aimed at three types of users:

- > The **system installer**, who wants a tool to monitor and, if necessary, fine-tune the system in the early stages of operation, thus offering the customer an advanced after-sales service without other costs.
- > The **advanced end user** who wants to control / monitor the system even when he is away from home (second homes, commercial / industrial buildings).
- > The **maintenance technician** who wants a tool to remotely monitor and modify the system and at the same time a tool to be informed in real time of any malfunctions or errors.

The REG Remote Management System is implemented by exploiting the technologies established in recent years, in particular cloud computing and mobile broadband communications.

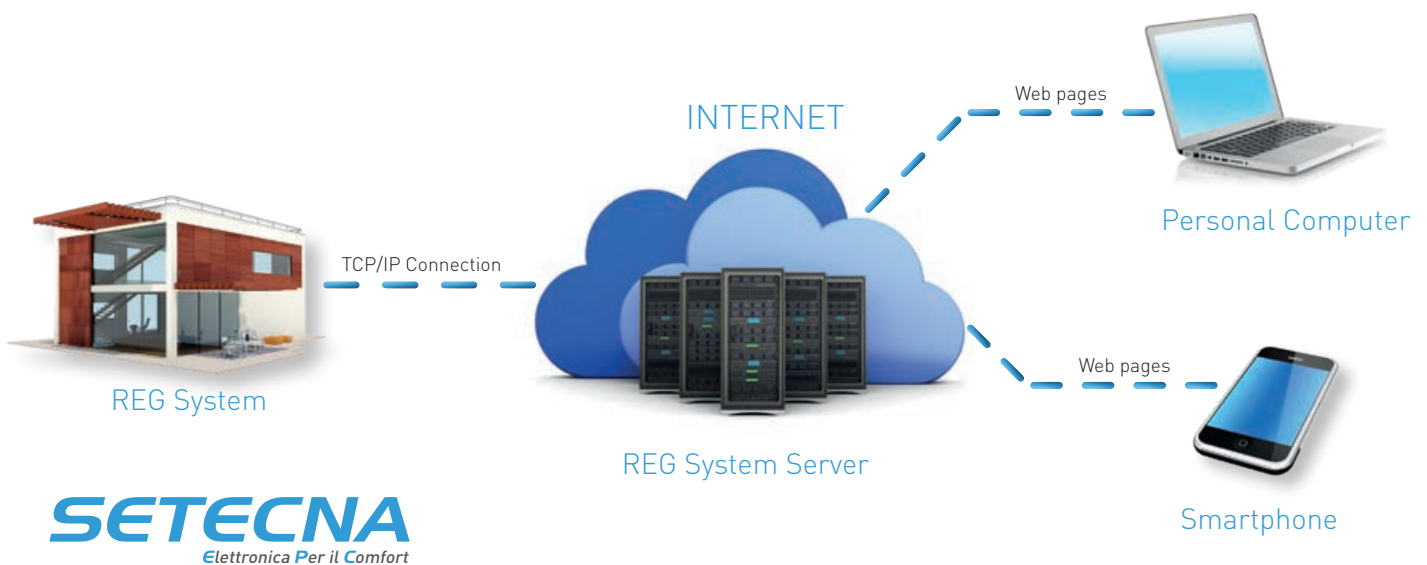

The type of technology to be used for the connection between the system and the server has three possible ways:

1. Via LAN connection
(product code: REG-LAN-MK2).
2. Via GSM / GPRS modem
(product code: REG-GSM).
3. Via Wi-Fi connection
(product code: REG-DOT-B).

The server is implemented in Cloud Computing mode; in particular, it is currently implemented in the European (Irish, to be precise) server farm of Amazon Web Services (AWS), the world's first cloud infrastructure operator.

The server uses an SQL database for data storage, a web server for the generation of web pages and proprietary drivers for communication with the REG PCB boards present on the systems.

All the software is based on Open Source systems, and the server itself uses the Linux operating system.

The primary server is assigned the address <https://s5a.eu>, protected by an SSL certificate issued by a recognized certification authority.

<https://s5a.eu>



> Cloud

Two levels of service are available:

- > **Basic Service**
- > **PRO Service**

All remote management systems, both Wi-Fi, LAN and GSM, have an initial period of four months of free PRO service.

This is intended to facilitate the installer in the early stages of system operation, to assist him with all the tools available (in particular the trends, very useful to understand if the system is working well or badly) in the post-commissioning phase.

About the Wi-Fi and LAN connection:

- > the Basic subscription is **free** and includes access to the system and the ability to view and modify all parameters also accessible from the RegConfig configuration software, to view alarms in real time and the system dashboard;
- > the Pro subscription is **subject to a fee** and adds to the Basic the display of trends and the alarm notification by email (valid for 2 years).

About the GSM connection:

- > the Basic subscription is **subject to a fee** and includes the SIM cost, access to the system and the ability to view and modify all the parameters also accessible from the RegConfig configuration software, to view the alarms in real time and the system dashboard (valid for 2 years);
- > the Pro subscription is **subject to a fee** and adds to the Basic the display of trends and the alarm notification by email (valid for 1 years).

To purchase Pro LAN, Pro GSM and Basic GSM subscriptions, a renewal voucher (code REG-VCR) must be bought from your REG System distributor.

The Remote Management system allows you to provide remote after sales assistance!

The RegConfig configuration software supplied with the REG System allows you to connect directly to the system remotely (Connect Via Web) and have access to all parameters as if you were directly connected via PC!

This tool allows you to provide 360° assistance both during commissioning and in the after sales phase!

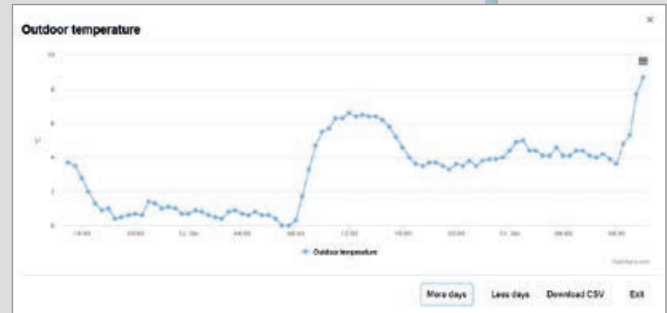

Check the system via APP!

The login ID and password are the same as those of the Web Server www.s5a.eu.



www.s5a.eu

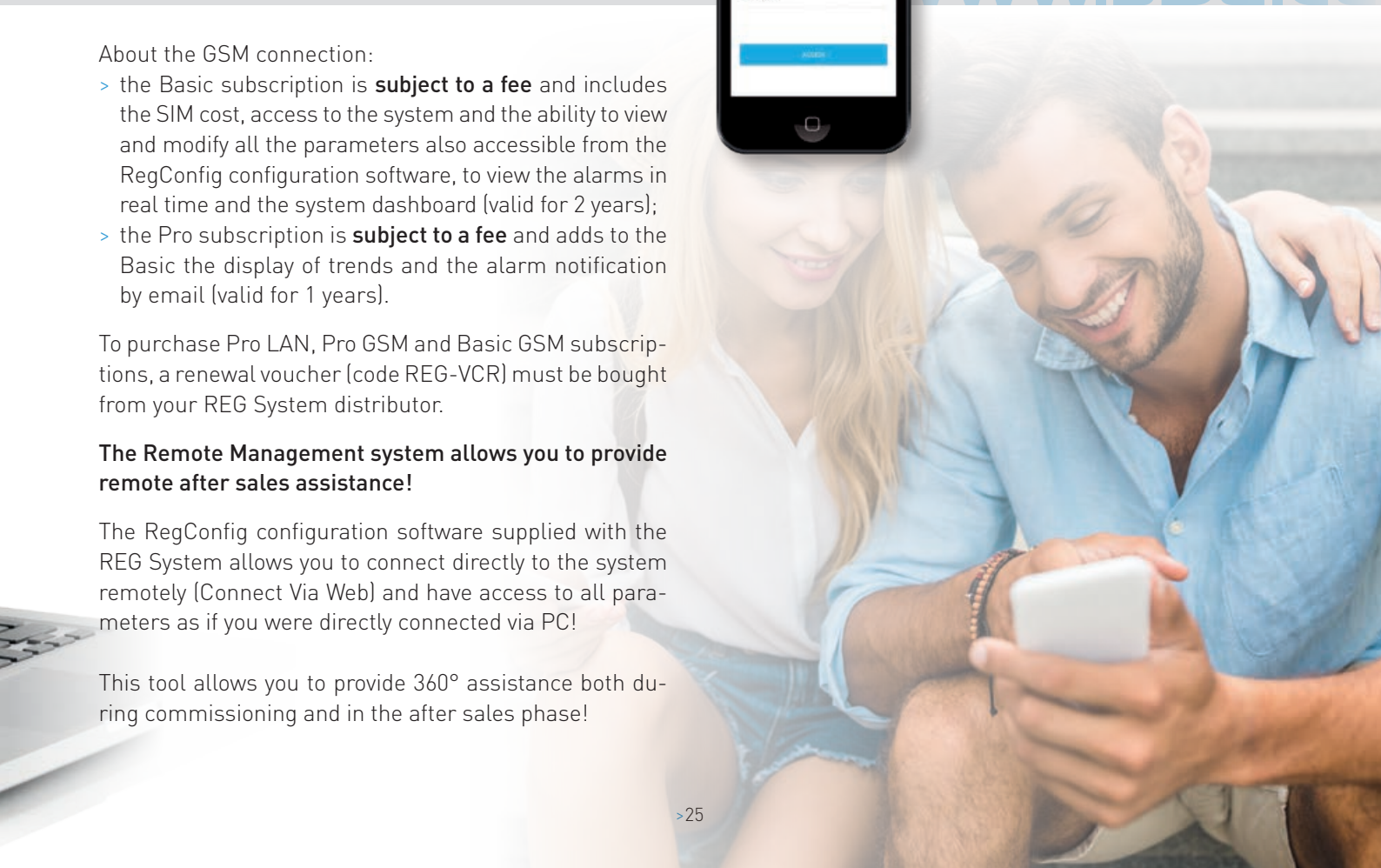

➤ Available Civil Series

CLASSIFICATION OF FLUSH-MOUNTED SENSORS AND REG-TFT DISPLAYS

STANDARD COVER		SLIM COVER	
S01	Vimar Plana Silver		
S02	Vimar Plana White		
S03	Vimar Idea White		
S04	Vimar Idea Black		
S05	Vimar Eikon White	S05E	Vimar Eikon White EVO
S06	Vimar Eikon Black	S06E	Vimar Eikon Black EVO
S07	Vimar Eikon Next	S07E	Vimar Eikon Next EVO
S50	Vimar Arké White	S50F	Vimar Arké White FIT
S51	Vimar Arké Black	S51F	Vimar Arké Black FIT
S52	Vimar Arké Metal	S52F	Vimar Arké Metal FIT
S10	BTicino International Black / Living Light Black	S10A	BTicino International Black AIR / Living Light Black
S11	BTicino Living Light White	S11A	BTicino Living Light White AIR
S12	BTicino Axolute White	S12A	BTicino Axolute White AIR
S13	BTicino Axolute Black	S13A	BTicino Axolute Black AIR
S14	BTicino Matix White		
S15	BTicino Living Light Tech	S15A	BTicino Living Light Tech AIR
S16	BTicino Axolute Silver	S16A	BTicino Axolute Silver AIR
S19	BTicino Matix Ivory		
S20	Gewiss System White		
S21	Gewiss Playbus Black <i>(phase-out)</i>		
S22	Gewiss Chorus White		
S23	Gewiss Chorus Black		
S24	Gewiss chorus Titanium		
S25	Gewiss System Black		

STANDARD COVER		SLIM COVER
S30	ABB Mylos White	
S31	ABB MYLOS Black	
S32	ABB Chiara White	
S40	Legrand Vela Black	
S41	Legrand Vela White	
S61	AVE Life Black	
S62	AVE Domus White sistema 44	
S63	AVE sistema 45	
S64	AVE Tekla black (matte) sistema 44	
S65	AVE ALLUMIA Silver Grey	
S66	AVE life Black (shiny) sistema 44	
S68	AVE domus class Ivory sistema 44	
S70	URMET Nea Aluminium Karbon - Dark Grey	
S71	URMET Nea Aluminium Satinato - Grey	
S72	URMET Nea Matte White	
S73	URMET Nea Charcoal Grey - Black	
S77	Bticino living NOW WHITE*	
S78	Bticino living NOW BLACK*	
S79	Bticino living NOW SAND*	
S80	In box 80x120 (TP-TH-TFT)	
S101	JUNG LS square Snow White	
S102	JUNG LS square Graphite Black	

The above Brands are registered trademarks owned by their respective Companies.

* For the REG-TFT display in the BTICINO NOW civil series it is necessary to use the code REG-TFT-NOW-SXX because the cost and the production is different, moreover it comes complete with the plastic cover.

SETECNA EPC s.r.l.

via Alessandro Volta, 19/B
37062 Dossobuono (VR) Italy

tel. +39 045 8600409

info@setecna.it | www.setecna.it

